



# SERVICE DIVISION

## DEALER TRAINING

AID # S1035

SUBJECT: 5-SPEED GEARBOX

MODEL: TR7

AUSTIN

JAGUAR

MG

LAND ROVER

TRIUMPH

## P R E F A C E

The information contained in this booklet is provided as an easy reference guide for technicians. More detailed information will be available in the appropriate Workshop Manual.

## I N T R O D U C T I O N

The 5-speed gearbox is an all new unit with a single rail gear selector. The gearbox is "77mm" between the mainshaft and the layshaft centers. It is, therefore, referred to as the 77mm gearbox.

### SHIFT PATTERN

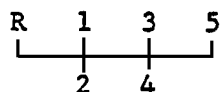

### RATIOS

1st	2nd	3rd	4th	5th	Reverse
3.321	2.087	1.396	1.0	0.833	3.428

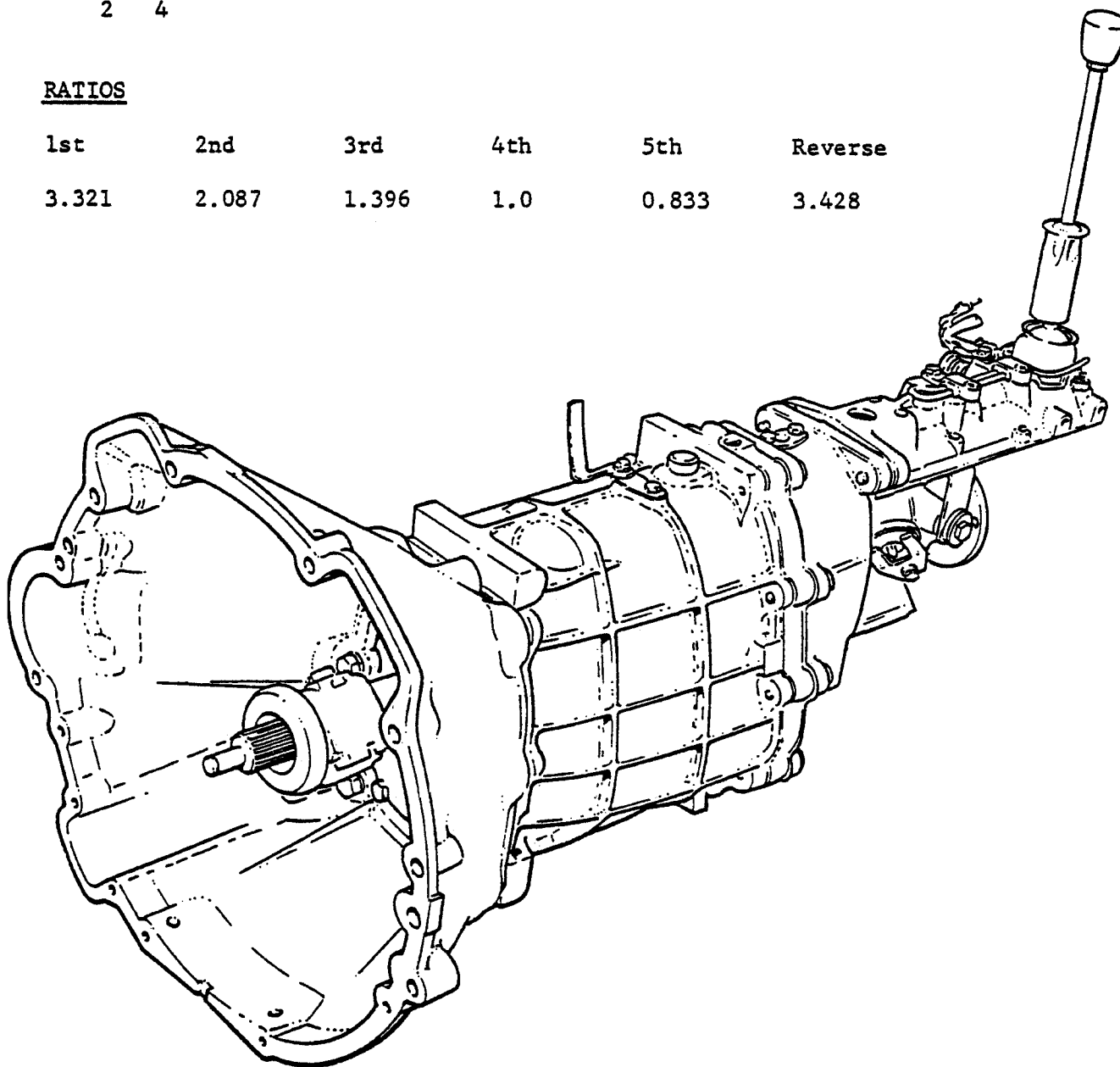

### TORQUE SPECIFICATIONS

	<u>ENGLISH</u>	<u>METRIC</u>
Clutch Lever Pivot Pin	30 lbs. ft.	3.5kg fm
Clutch Housing to Gear Case Bolts	55 lbs. ft.	7.5kg fm
Oil Inlet Access Hole Blanking Screw	15 lbs. ft.	2.0kg fm
Bias Spring Attachment Bracket Bolts	5 lbs. ft.	0.7kg fm
Reverse Baulk Plate Attachment Bolts	5 lbs. ft.	0.7kg fm
Gear Lever Dust Cap Bolt	5 lbs. ft.	0.7kg fm
Remote Control Housing to Extension Casing Bolts	15 lbs. ft.	2.0kg fm
Coupling Flange Self Locking Nut	150 lbs. ft.	20.0kg fm
Extension Casing to Gear Casing Bolts	18 lbs. ft.	2.5kg fm
Interlock Spool Locating Plate Bolts	5 lbs. ft.	0.7kg fm
Pinion/Layshaft Bearing Front Cover Bolts	18 lbs. ft.	2.5kg fm
Oil Pump Cover Bolts	5 lbs. ft.	0.7kg fm
5th Speed Selector Fork Support Bracket Bolts	18 lbs. ft.	2.5kg fm
Reverse Pivot Pin Retaining Nut	18 lbs. ft.	2.5kg fm

### CLEARANCES AND TOLERANCES

End Float in Mainshaft/Pinion Bearings	.002-.004 in.	0.06-0.11mm
End Float in Layshaft Bearings	.001-.003 in.	0.03-0.08mm
Clearance Between Mainshaft Rear Bearing and Circlip	Zero-.002 in.	1.005-0.05mm
Thrust Clearance in 1st Gear	.003-.008 in.	0.08-0.17mm
Thrust Clearance in 2nd Gear	.002-.008 in.	0.07-0.17mm
Thrust Clearance in 3rd Gear	.002-.008 in.	0.07-0.17mm
Thrust Clearance in 5th Gear	Zero-.002 in.	0.005-0.050mm

Clearances and Tolerances (Cont.)

	<u>ENGLISH</u>	<u>METRIC</u>
Reverse Baulk Plate Load Setting	25-30 lbs.	11.00-13.00kg
Run Out of Coupling Flange Face	.002 in. in Max.	0.05mm Max.
Run Out of Coupling Flange Spigot Dia.	.004 in Max.	0.10mm Max.

OIL TYPE AND CAPACITY

Hypoid Gear Oil SAE 80	2.9 pints	1.6 litres
------------------------	-----------	------------

## STRIP AND REBUILD

### TOOL

1. Remove clutch withdrawal fork by removing clutch pivot bolt.

Snap On Wrench ST1136  
or 19mm crowfoot

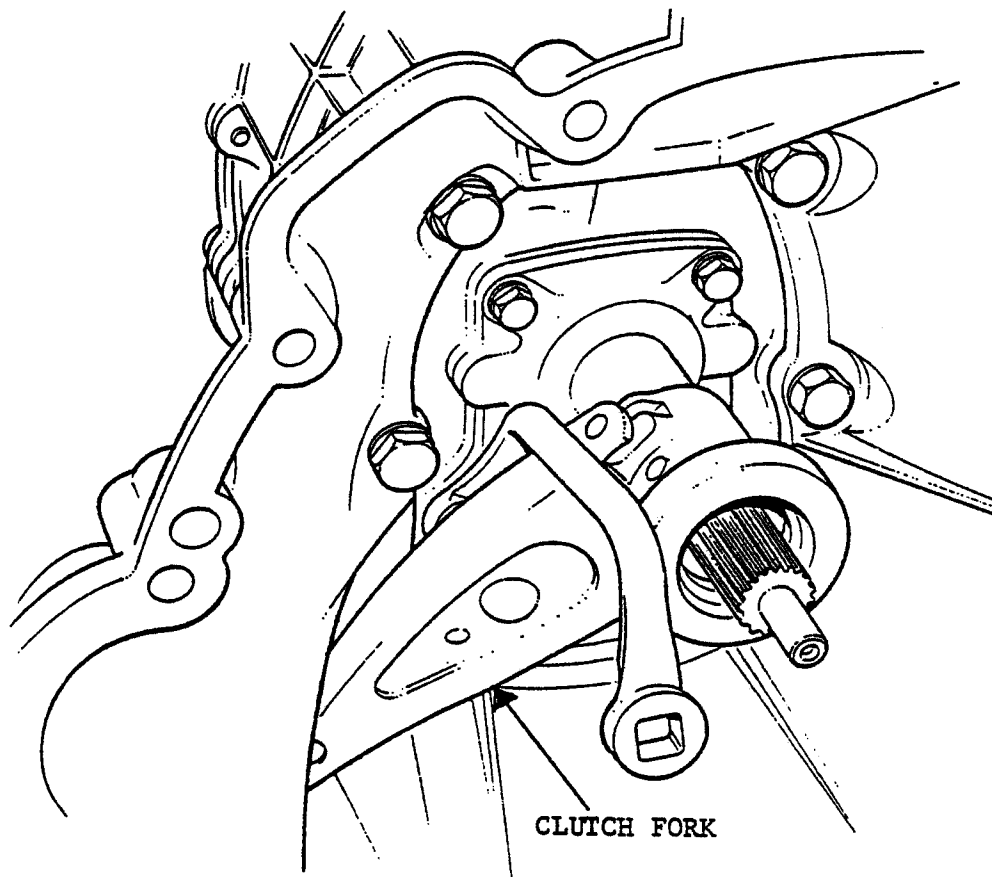

2. Remove 6 bolts from bell housing.

19mm Socket

NOTE: 2 longer bolts in dowel locations have a plain washer in addition to spring washers.

Remove bell housing.

TOOL

3. Remove 6 bolts and take off front cover. Note shims behind cover for mainshaft and layshaft end floats. Remove gasket and bearing cups.

13mm Socket

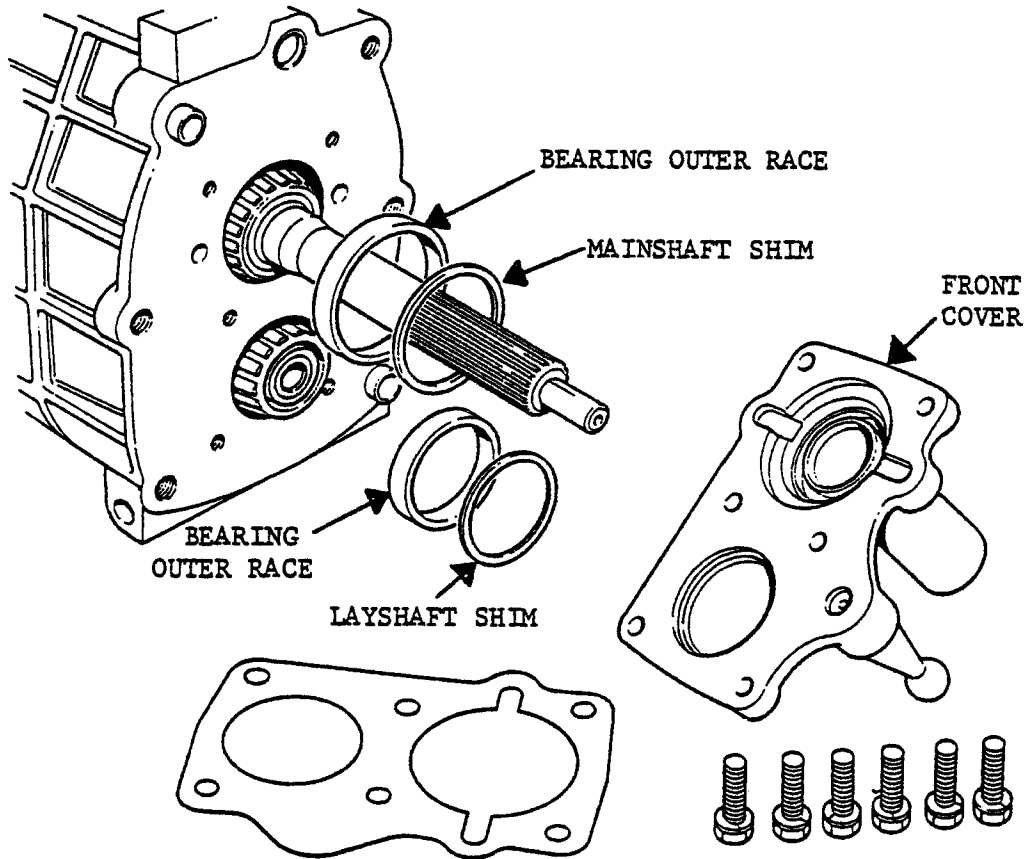

4. Using flange holder remove rear flange. If tight, use two legged puller. Do not hammer. Damage to the flange may induce transmission vibration.

18G1205

27mm Socket

18G2

TOOL

5. Through access hole in rear extension remove nyloc nut from selector rail coupling pin.  
Remove plain washer and drift out coupling pin.

13mm Socket

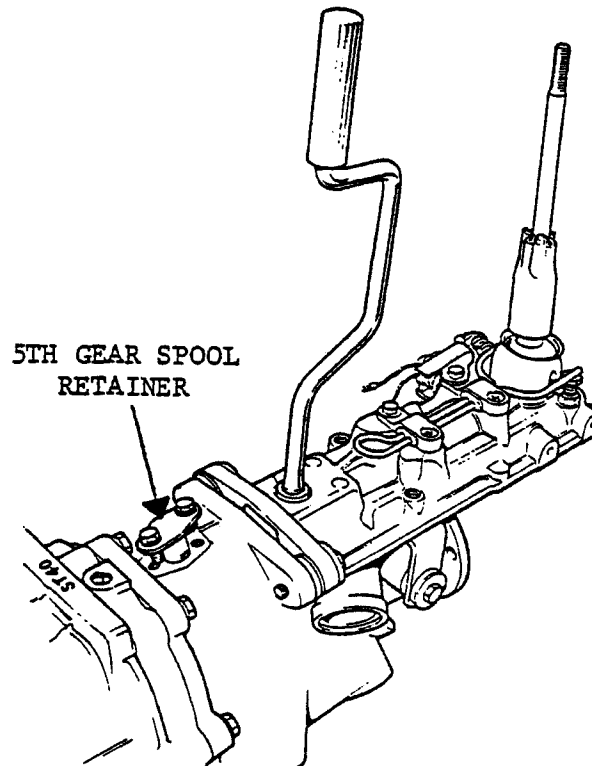

6. Remove 5th gear spool retainer.
7. Remove 10 bolts that secure extension housing to the main casing.

10mm Socket - Pliers

13mm Socket

NOTE: 2 longer bolts in dowel locations.



TOOL

8. Remove rear extension. Temporarily secure center plate to main casing using 2 front cover bolts. Retrieve square pump drive shaft - will be loose.

13mm Socket

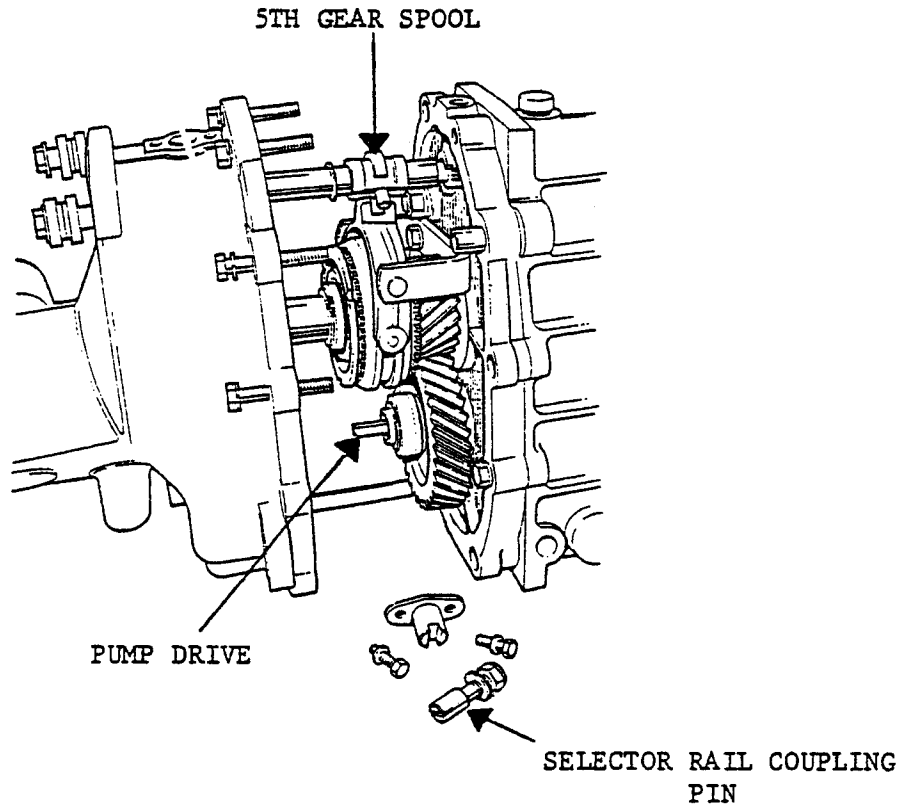

9. Lever plastic cap and unscrew breather from main case.

Screwdriver

NOTE: If it is not removed, the breather can be damaged as the main case is lifted.

TOOL

9a. Retained in the extension housing will be the following components:

Oil Pick Up Pipe  
Speedo Gear                      loose  
Collar                              loose  
Bearing  
Seal

10. Remove clip from selector rail.                      Screwdriver

11. Remove 2 clips from 5th speed fork pivot pins.                      2 Screwdrivers

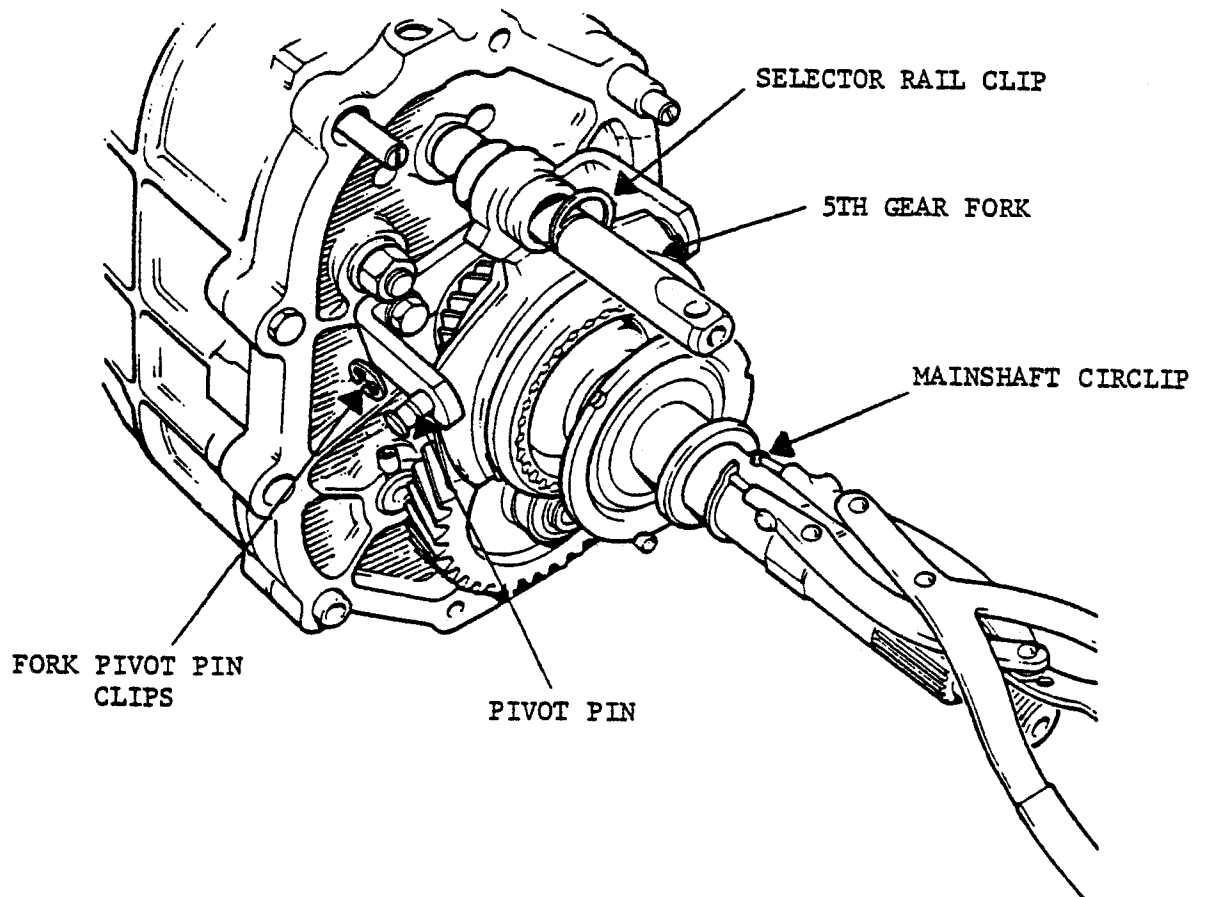

TOOL

12. Remove 2 pivot pins.
13. Slide back spool and remove fork complete with two shoes and spool assembly.
14. Remove mainshaft circlip retaining 5th speed synchro hub.
15. Remove selective washer.

Circlip Pliers

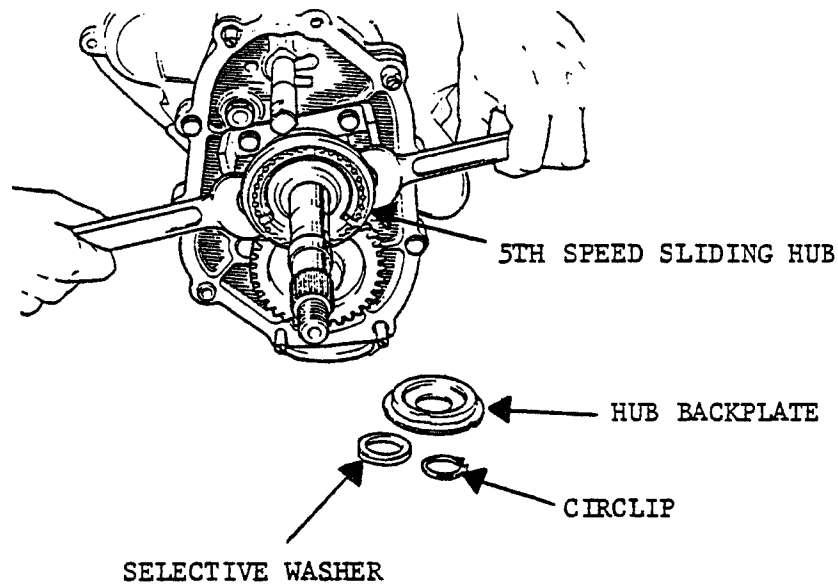

16. Remove hub backplate.
17. Remove synchro hub.

2 Levers

NOTE: If synchro hub is tight on mainshaft splines, ease off by levering behind 5th gear removing synchro hub and gear together.

TOOL

18. Remove 5th speed gear with two caged needle roller bearings.
19. Remove thrust washer.
20. Install four dummy studs 60mm long into the two top and two bottom bolt holes of the main case.
21. Remove the circlip from layshaft 5th gear and retaining collar using the special tool.

4 Fabricated Studs

Circlip Pliers

18G705-1

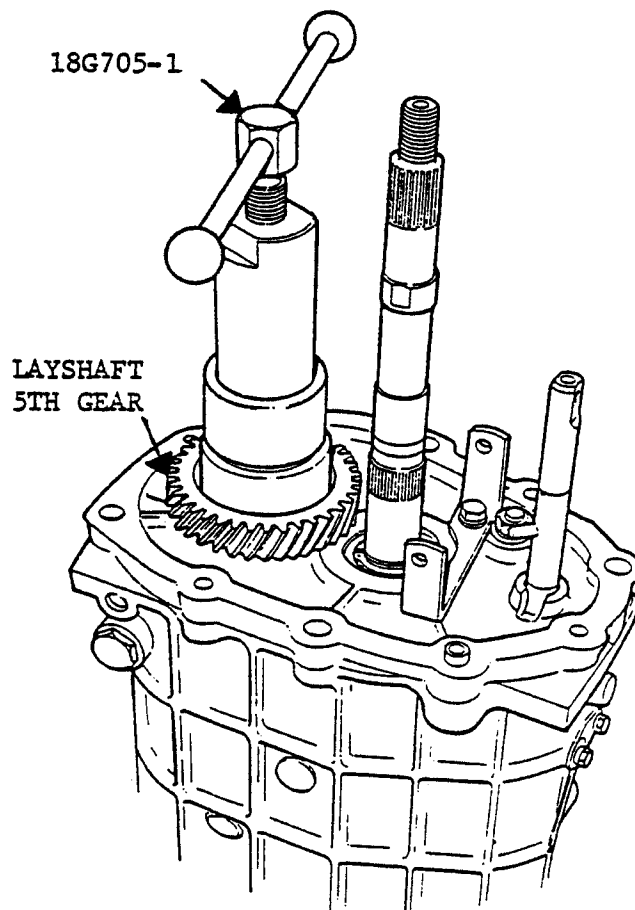

TOOL

22. Remove reverse shaft.
23. Invert gearbox and mount on suitable stand or in vise with front of gearbox uppermost. The 4 studs should be positioned in locating bosses if stand is used.
24. Remove spool retainer from main casing.

10mm Socket

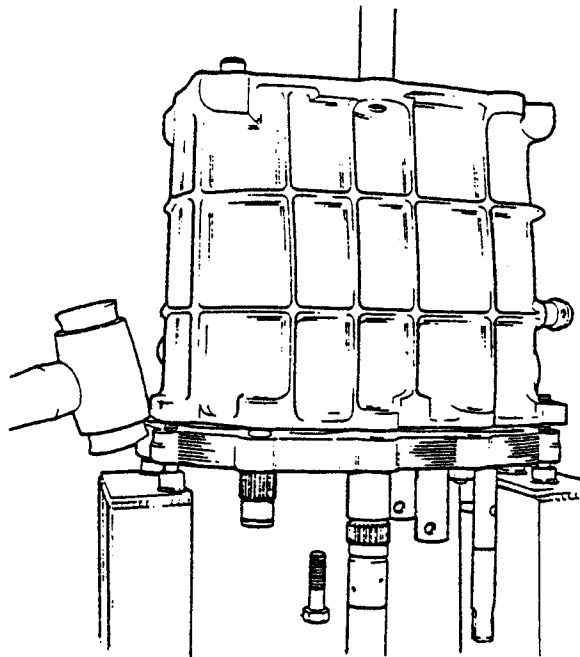

25. Remove front cover bolts holding the center plate to the main casing and tap center plate down onto stand and lift off main case.

13mm OE or Socket

TOOL

13mm

26. Insert the 2 front cover bolts through center plate to locate plate onto stand.

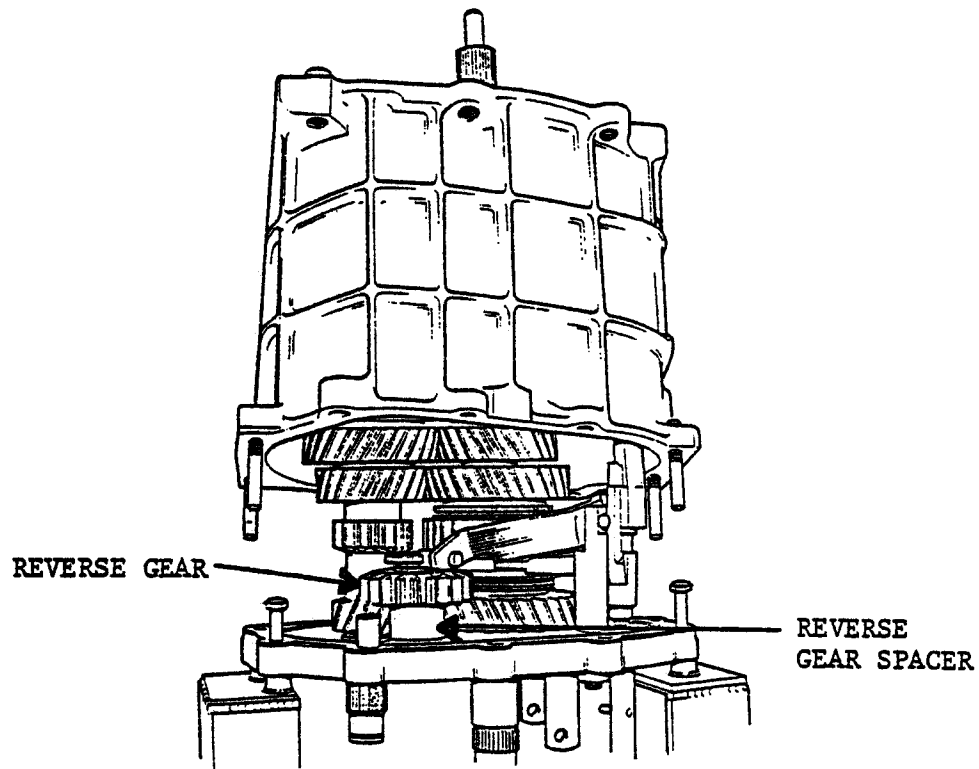

27. Lift off reverse gear and distance piece.
28. Tilt the layshaft away from the mainshaft. Remove the layshaft, first motion shaft and synchro cone.

TOOL

29. Rotate the selector rail anticlockwise (viewed from above) until the 1st gear selector pin frees reverse crossover lever. Remove clip and pivot.

14mm OE

Small Screwdriver

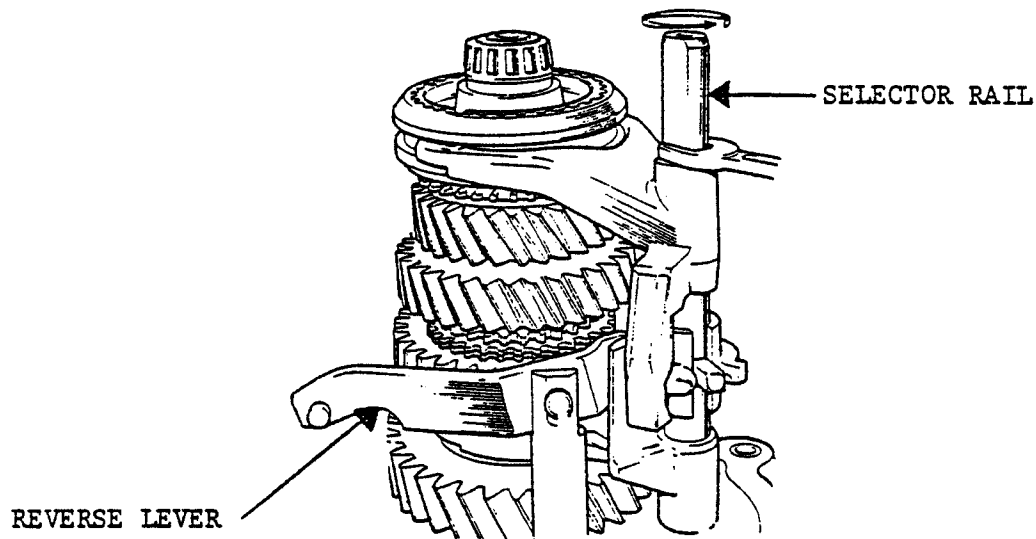

30. Remove the detent screw, spring and ball.

Screwdriver

Magnet

31. Rotate the selector shaft clockwise to align 5th gear selector pin with slot in center plate.

14mm OE

TOOL

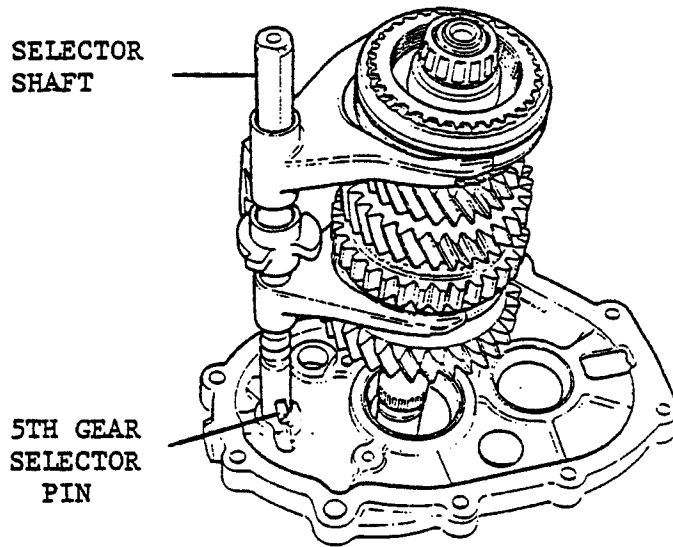

32. Remove the mainshaft and selectors as an assembly.
33. Dismantle the selectors from the mainshaft.
34. Dismantle mainshaft. Remove circlip from behind center bearing.
35. Mount mainshaft in universal hand press and extract center bearing using special tools.
36. Remove from rear of shaft:
  - 1st gear and bush
  - 1st gear synchro cone
  - 1st/2nd synchro hub
  - 2nd gear synchro cone
  - 2nd gear

Circlip Pliers

18G47-3



TOOL

S422A-10

37. Place mainshaft in hand press supporting  
3rd gear and using special tools.
38. Press out mainshaft using suitable mandril.

This will remove:

3rd gear

3rd gear synchro

Distance washer

Pilot bearing

39. Inspection

Check all parts for wear and damage.

Mainshaft - Parker luberised (dark color)

- serrated surfaces providing oil  
feed to gears
- drillings for pressure lubrication  
from pump, restrictor pins in feed  
holes. Ensure drillings are clear.

- Gears
- Check gears for chipping and wear
  - Check synchro cone contact area for  
damage and blueing
  - Examine dog teeth

TOOL

NOTE: 2nd synchro cone is different from the 1st,  
3rd, 4th and 5th.

2nd synchro cone is colored 'green' for  
identification.

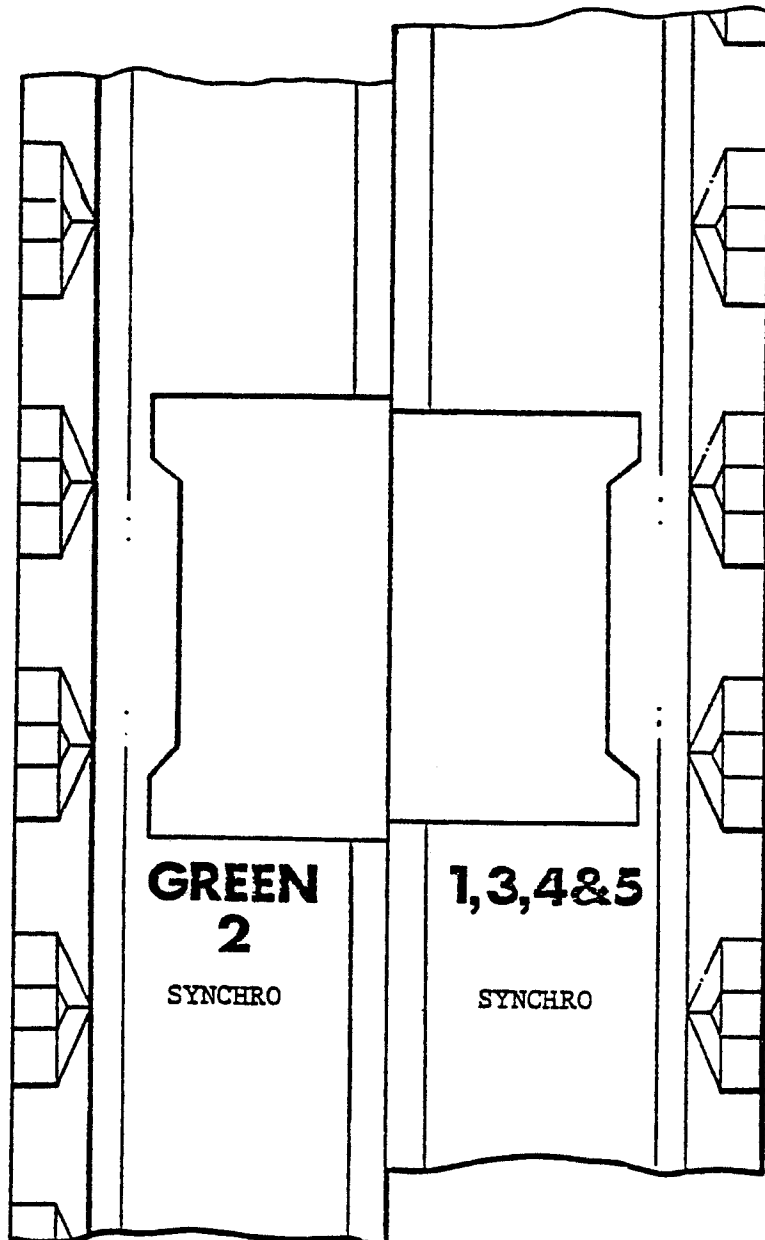

40. Check wear between synchro cones and gears by pushing cone onto gear and measure gap between them.

Minimum clearance 0.64mm (.025 in.)

Inspect 1st gear selective bush and 5th speed caged needle roller bearings and replace if necessary.

41. 'Mitred Tooth'

The main advantage of the 'Mitred Tooth' system is that it provides a very effective 'in-gear' lock when accelerating or decelerating. It also allows lighter loading of selector springs and gear lever, and is used on all forward gears in the 5-speed gearbox.

The diagram shows the 'Mitred Tooth' under acceleration which forces the gear harder into engagement.

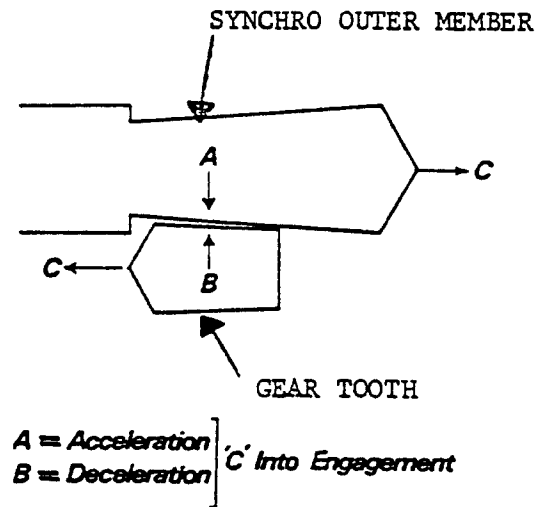

42. 'Staggered Splines'

This system which is very positive may be designed to provide drive or overrun locking. In the 5-speed gearbox it is employed to supplement the mitred tooth system on 1st gear only. The diagram shows how the inner and outer members are locked together by the staggered splines.

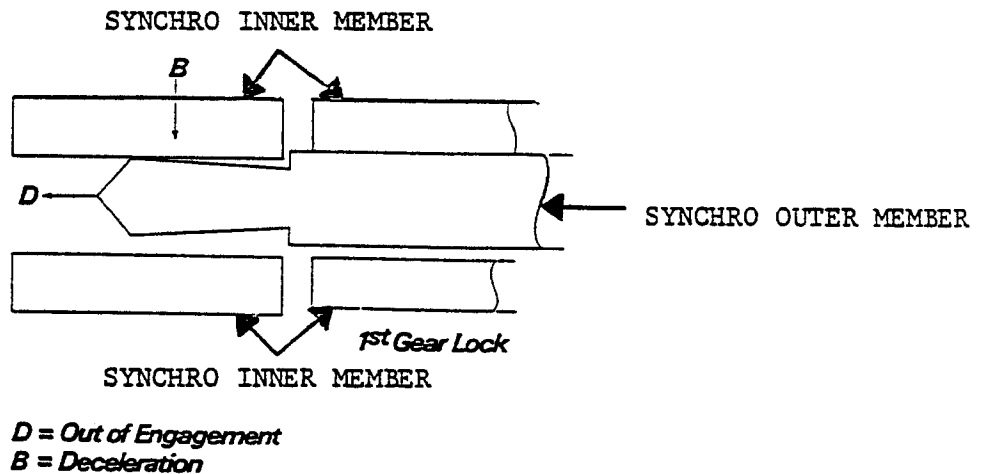

43. 1st Gear Bush End Float

The end float of 1st gear bush is controlled by selective assembly of the bush which is available in 5 different sizes. The variation in these sizes is in the width of the flange on the bush.

TOOL

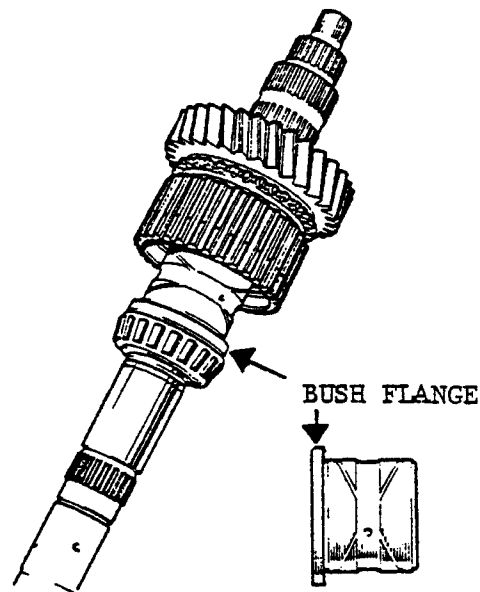

NOTE: There is no means of adjusting the end float of the gears. This is determined by accurate machining of the components. In order to make the selection of the bush easy, it is advisable to manufacture a dummy spacer or increase the bore of an old center bearing so that it is a sliding fit on the mainshaft.

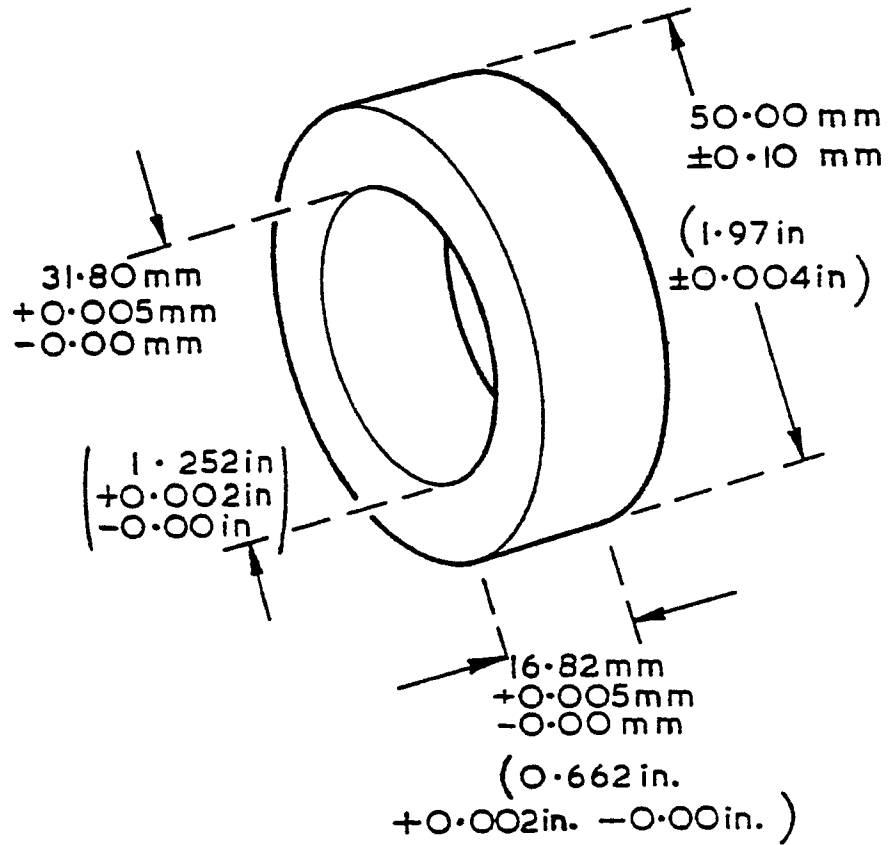

DIMENSIONS OF DUMMY BEARING

44. Selection of Bush

To determine the correct size bush, assemble the following components to the rear of the shaft:

2nd gear

1st, 2nd synchro hub

1st gear bush

Dummy spacer and circlip

Ensure the dummy spacer is pressed back against the circlip to allow the bush maximum end float. Feeler gauge

The bush must be free to rotate easily with (Zero in.) 0.005mm to (.002 in.) 0.05mm end float.

Bush sizes and part numbers:

TKC 1477	40.12mm to 40.18mm	1.579 to 1.581 in.
TKC 1478	40.18mm to 40.23mm	1.581 to 1.583 in.
TKC 1479	40.23mm to 40.28mm	1.583 to 1.585 in.
TKC 1480	40.28mm to 40.33mm	1.585 to 1.587 in.
TKC 1481	40.33mm to 40.38mm	1.587 to 1.589 in.

The 2nd gear synchro cone has wider slipper slots to allow the cone more freedom for easy engagement and is stained green for identification. The 2nd synchro cones and 1-3-4-5 synchro cones must be kept to the original locations and are not interchangeable.

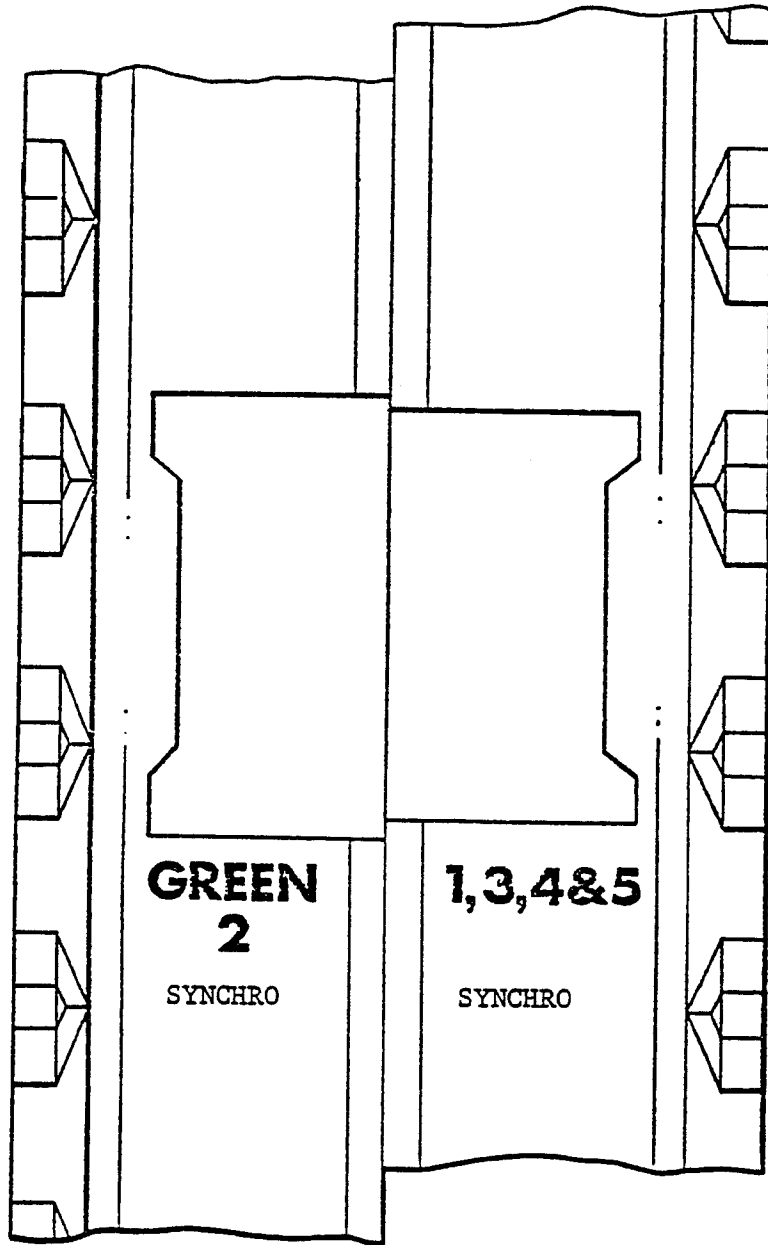



TOOL

46. Bearings

NOTE: The center bearing track is a slide fit in the center plate.

Check all bearings examining for pitting, wear and damage.

47. Check fit of synchro hubs on mainshaft ensuring excessive play is not present between hub splines and shaft splines.

48. 3rd/4th Synchromesh

The 3rd/4th synchro outer member may be assembled to the inner member either way round, however, on initial assembly the synchro members are marked with paint which should be re-aligned.

The projection on the inner member must face to the front of the mainshaft.

49. 1st/2nd Synchromesh

The 1st/2nd synchro inner and outer members must be assembled correctly. Any paint marks should be re-aligned.

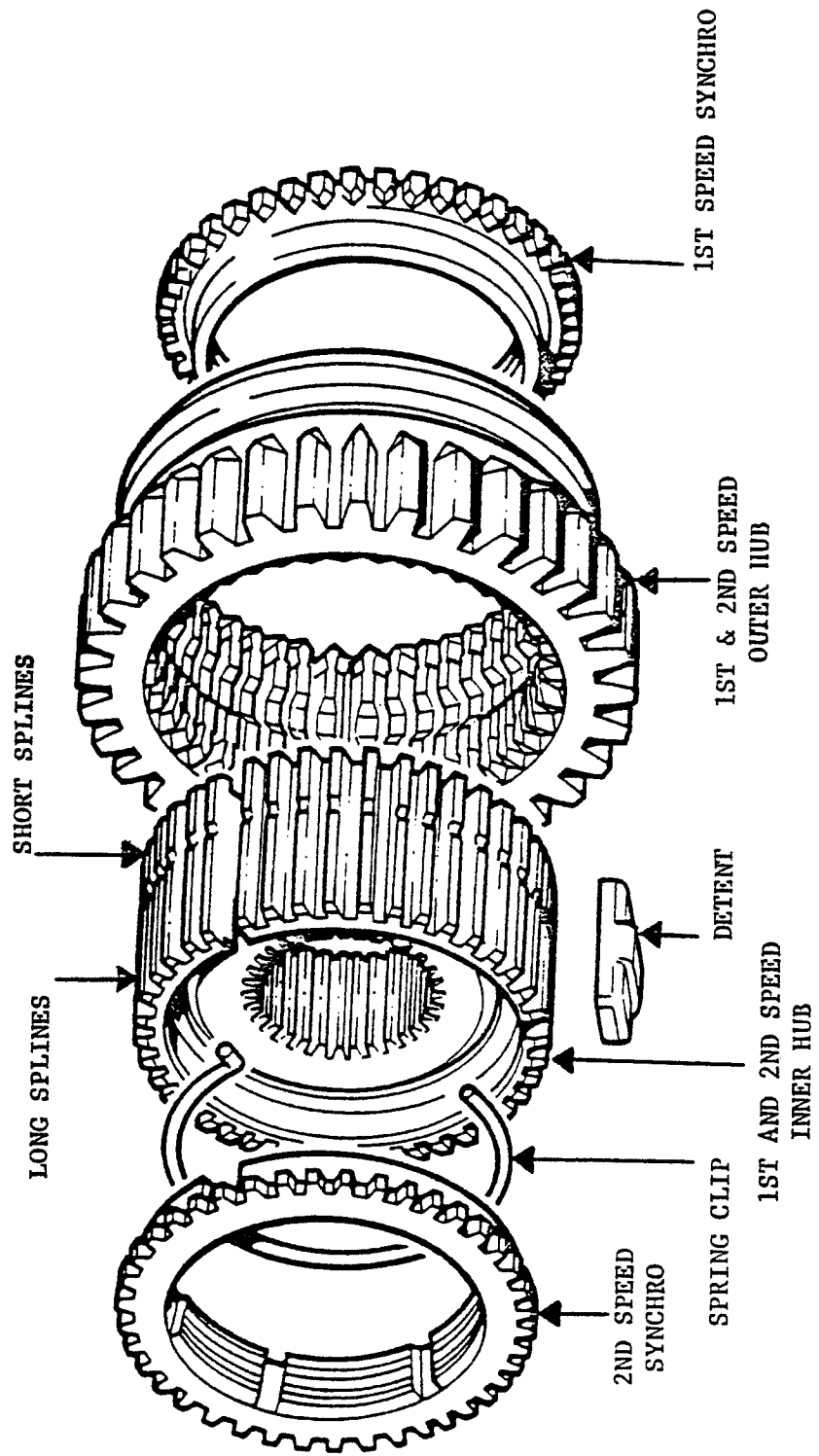

TOOL

If there are no paint marks, ensure that the inner member external (short splines) are towards 2nd gear on mainshaft.

NOTE: Long splines are notched.

50. Assemble the gear components to the rear of the shaft 2nd speed gear, synchro cone (green), 1st and 2nd speed hub with outer sleeve slot facing rearward, synchro cone and 1st speed gear and bush. Press the center bearing onto the shaft. Fit circlip.

Circlip Pliers

NOTE: Detents - Open end faces hub center.

Both spring hooks must not contact same detent.

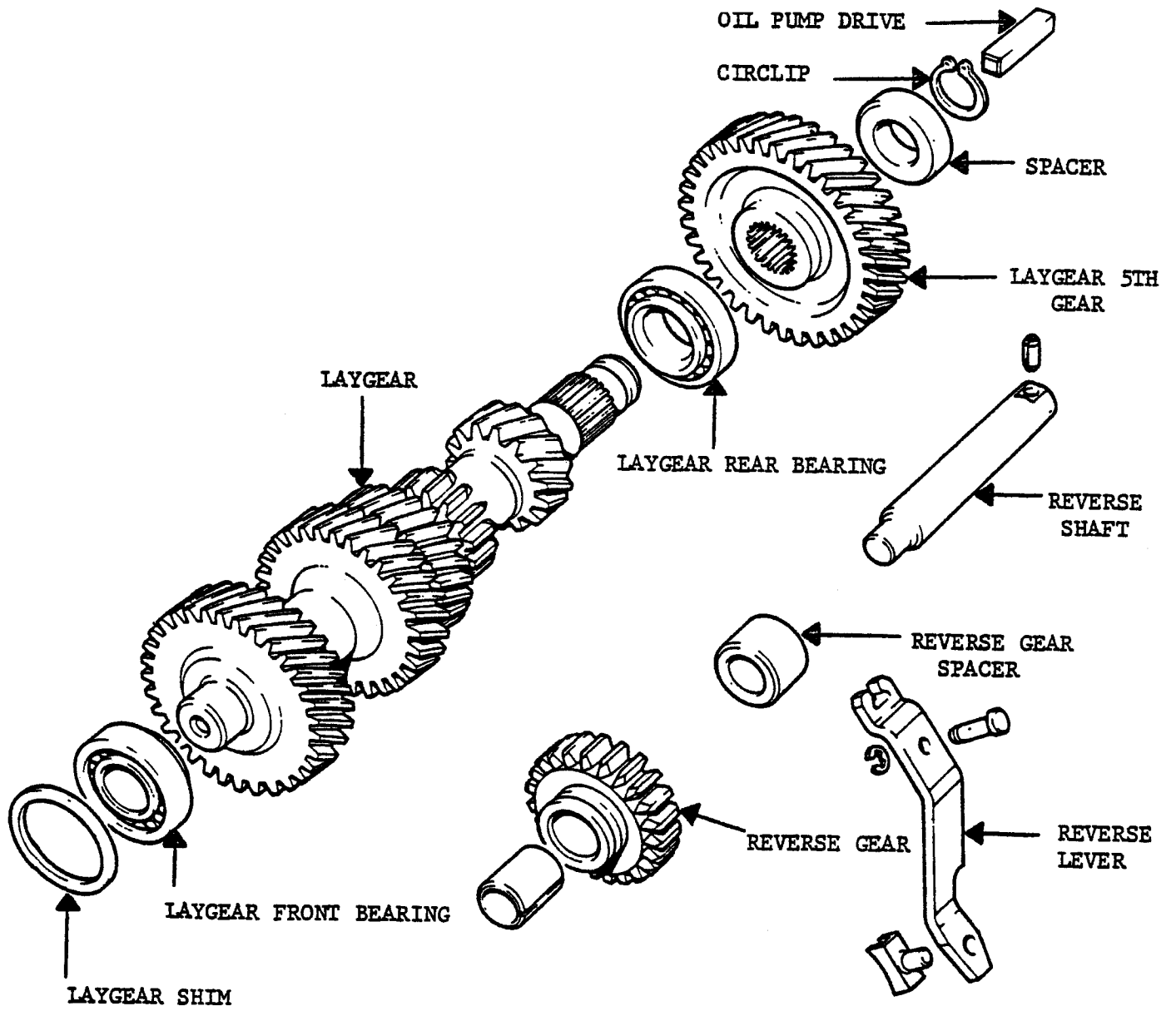

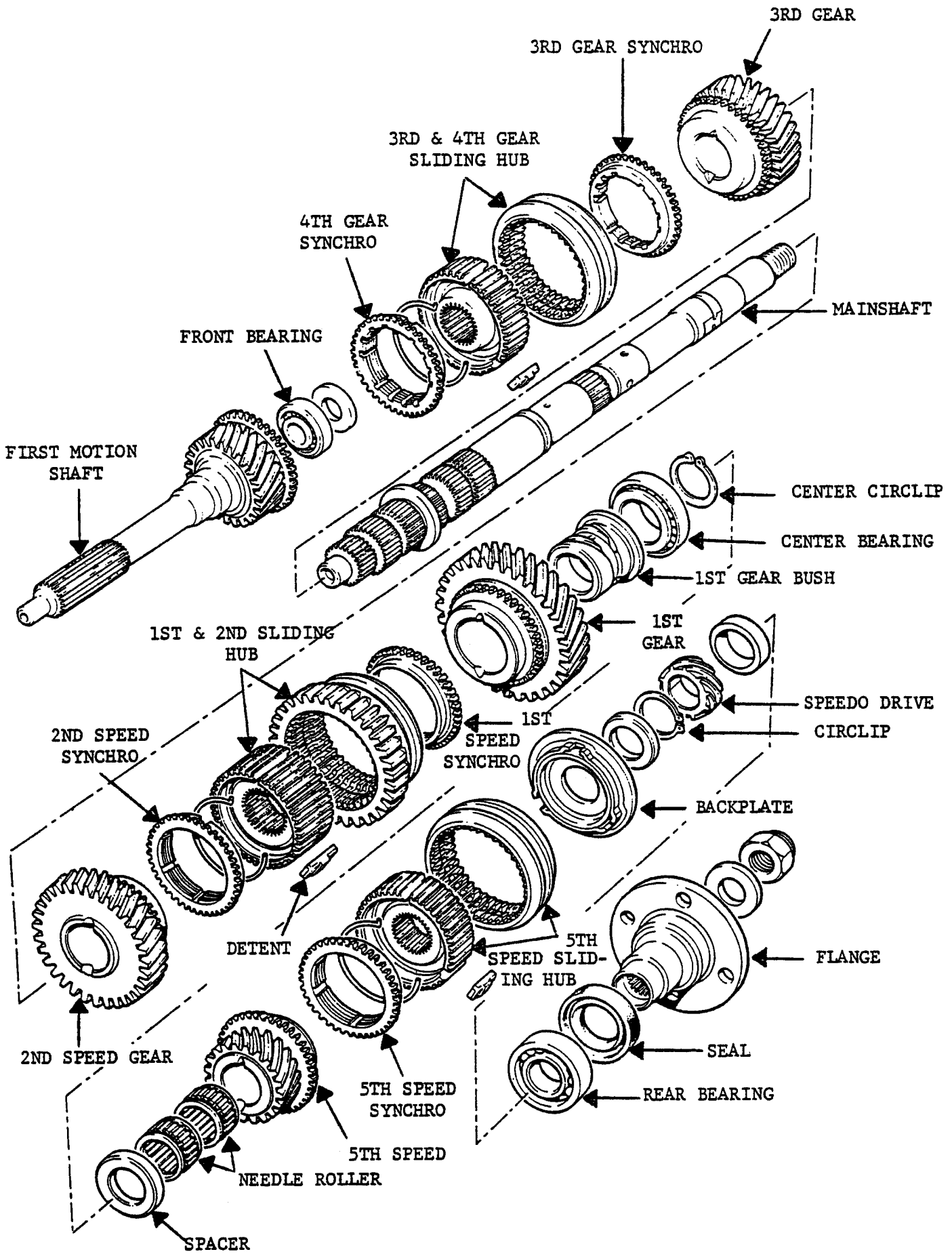

TOOL

51. Assemble front end of mainshaft.

Slide on 3rd gear, 3rd gear synchro cone and 3rd/4th synchro hub, projection on inner hub facing forward. Fit spacer washer and pilot bearing (drift on using suitable tube).

NOTE: There is no means of adjusting the end float of the gears. This is determined by accurate machining of the components.

NOTE: The center plate and main casing are supplied as a unit under one part number.

52. Assemble mainshaft and selectors correctly prior to installing complete assembly into the center plate, ensuring that the 5th gear selector pin passes through the slot in the center plate.

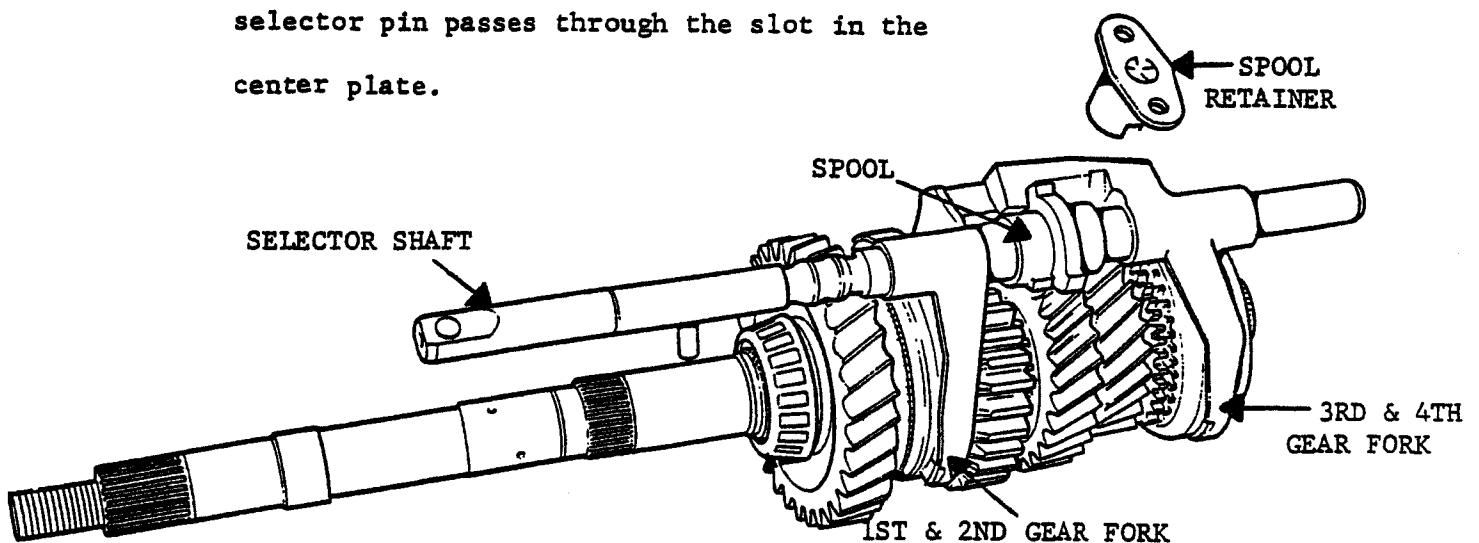

TOOL

53. Ensure that 3rd/4th synchro outer member is not dislodged as the mainshaft assembly is lowered into position.
54. Install the laygear, reverse shaft, distance piece and gear - slot towards front of box.
55. Invert the complete assembly supporting the front of the mainshaft and layshaft on suitable blocks of wood and press on the 5th gear and collar. Ensure groove on 5th gear center hub faces outwards. Fit circlip. Place the assembled block onto the bench stand.

Circlip Pliers

Screwdriver

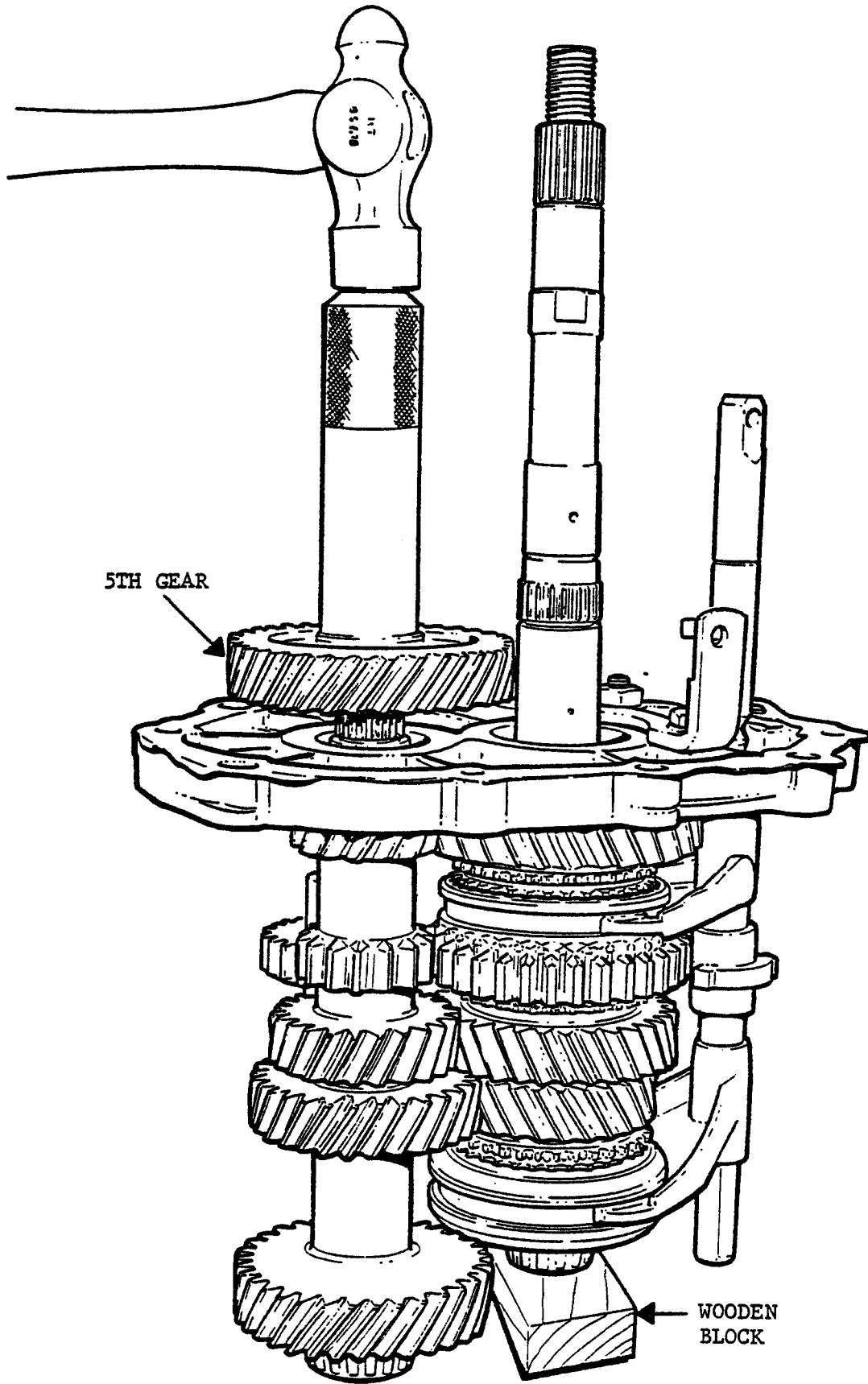

5TH GEAR

WOODEN  
BLOCK



TOOL

Small Screwdriver

56. Fit the reverse lever, pivot and clip.
57. Fit 4th gear synchro cone and first motion shaft.

NOTE: If fitted at this stage, it is possible for the gearbox breather to catch on the 3rd/4th speed spool as the casing is lowered into position.

58. Rotate the selector rail a little clockwise to align the selector pin with 3rd/4th selector fork, (to allow fitment of spool retainer later).

14mm OE

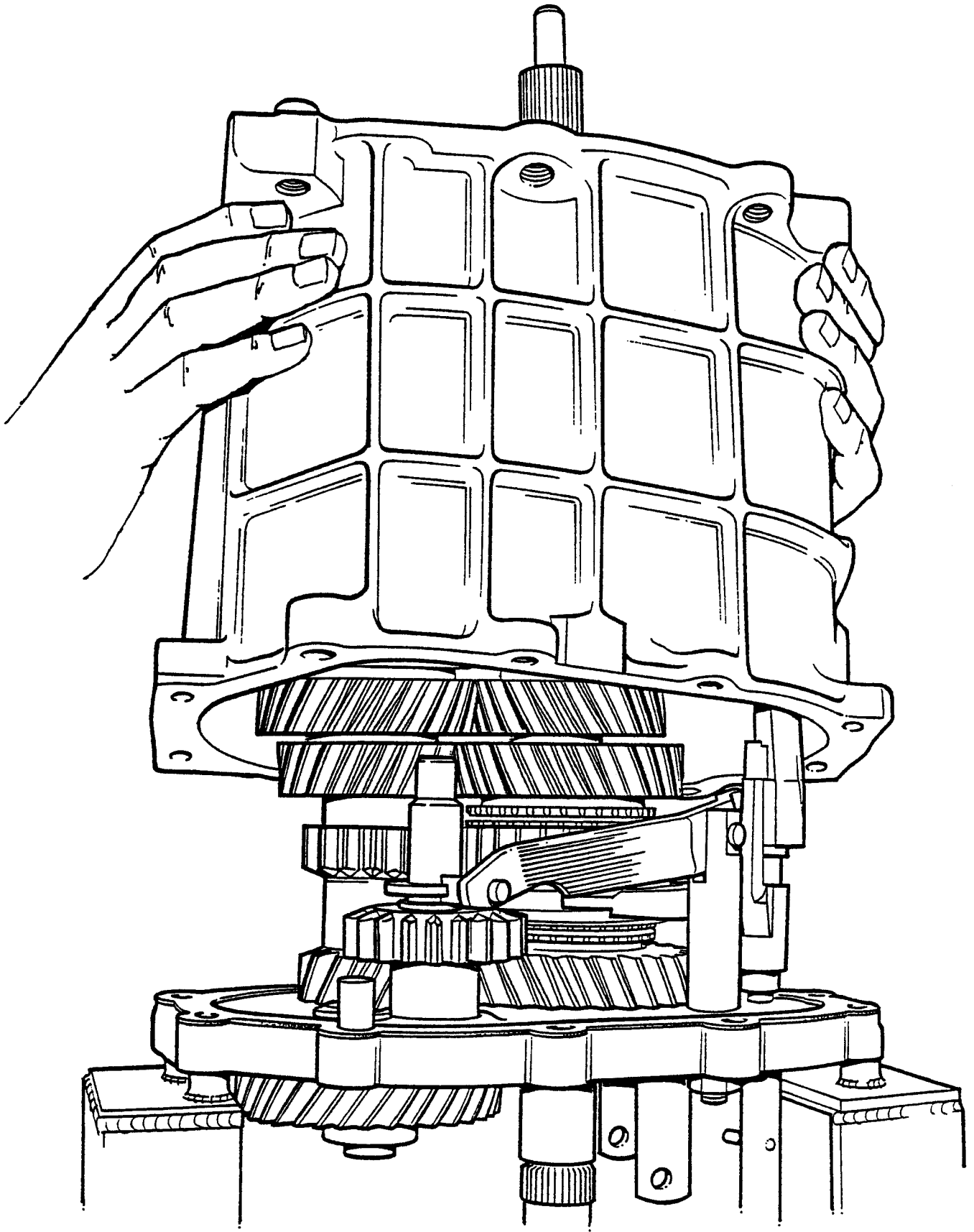

TOOL

59. Remove studs from main case and attach gasket to casing using a light smear of grease. Lower casing onto center plate engaging the two dowels.
60. Attach center plate to main casing using the 4 bolts from front cover plate and plain washers and tighten to 18 lbs/ft. prior to calculating mainshaft and layshaft end float.
61. Refit the 3rd/4th gear spool retainer, breather and selector detent ball spring and plug, center punch casing and plug.
62. Calculating mainshaft and layshaft end float shims, place the layshaft and first motion shaft bearing tracks in position. Wind tape around first motion shaft just below splines to centralize shaft in front cover housing preventing rocking action when measuring mainshaft end float. Fit front cover and gasket, but no shims. Tighten 4 cover bolts to 18 lbs/ft.

13mm Socket  
Torque Wrench  
10mm  
Screwdriver  
Center Punch  
Hammer

13mm Socket  
Torque Wrench

TOOL

Dial Gauge

63. Mount dial gauge on front gearbox surface, stylus on first motion. Measure mainshaft end float (first motion shaft and mainshaft to be considered as one for the purpose of this exercise).

Example:

	<u>MM</u>	<u>INCHES</u>
Mainshaft end float	= 1,70mm	- .067
Selected shim	= 1,65mm	- .065
End float	= 0,05mm	- .002
Mainshaft specified float	= 0,005mm to = 0,055mm	- .0002 to - .002

Shims Available

1,40mm	.055"	2,05mm	.080"
1,50mm	.059"	2,11mm	.083"
1,60mm	.062"	2,17mm	.085"
1,69mm	.066"	2,23mm	.087"
1,75mm	.069"	2,29mm	.090"
1,81mm	.071"	2,35mm	.092"
1,87mm	.073"	2,41mm	.094"
1,93mm	.075"	2,47mm	.097"
1,99mm	.078"	2,53mm	.099"
1,99mm	.078"	2,59mm	.102"

TOOL

64. Remove front cover and fit selected mainshaft shim. A shim must also be fitted to the layshaft in order to check end float. If no shim is fitted the layshaft will foul the front cover giving a false reading.

13mm Socket

65. Remove tape 'packing' from first motion shaft. Replace gasket and front cover. Tighten 4 bolts to 18 lbs/ft.

66. Mount dial gauge on rear face of gearbox and measure layshaft end float direct by raising 5th speed gear.

Dial Gauge

Layshaft specified float = 0,005mm - .0002"  
to to  
0,55mm - .002"

Shims available

1,69mm	.066"
2,75mm	.108"
2,81mm	.110"
2,87mm	.112"
2,93mm	.115"
2,99mm	.117"
2,05mm	.080"
2,11mm	.083"
2,17mm	.085"
2,23mm	.087"

TOOL

- 67. Remove front cover.
- 68. Install seal, oiling sealing lip for initial lubrication.
- 69. Tape input shaft to protect seal from sharp edges of spline.
- 70. Replace gasket and cover. Tighten bolts to 18 lbs/ft. 13mm Socket  
Torque Wrench
- 71. Remove gearbox from stand and assemble:
  - a. Spacer washer - non-selective
  - b. 5th speed gear and both caged needle rollers
  - c. Synchro cone
  - d. 5th speed synchro hub (projection on inner hub to rear) 18G1197
  - e. Hub backplate
  - f. Selective fit washer Circlip Pliers
  - g. Circlip

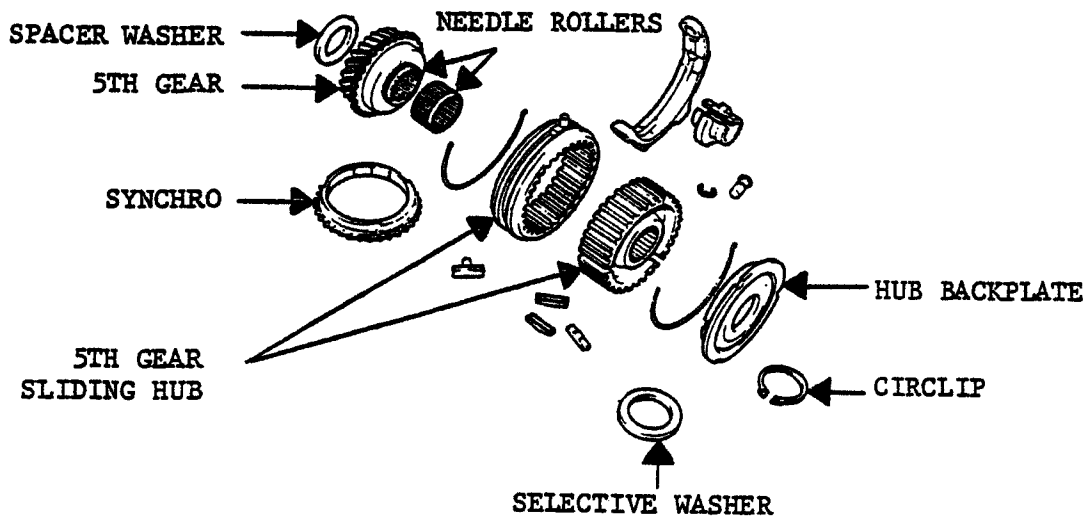

TOOL

72. Insert feeler between spacer washer and 5th gear, and measure float.

Feeler Gauge

Specified float = 0.005mm - .0002"  
                  to                  to  
                  0.055mm - .002"

Selective Washer Sizes Available:

5.105mm	.200"	5.410mm	.212"
5.182mm	.204"	5.486mm	.215"
5.258mm	.207"	5.563mm	.219"
5.334mm	.209"	5.639mm	.222"

73. Assemble 5th speed selector fork and spool to selector rail, large flange on spool to fork and largest area of fork to rear. Install fork retaining pins and clips. Locate spring clip on rail.

Screwdriver

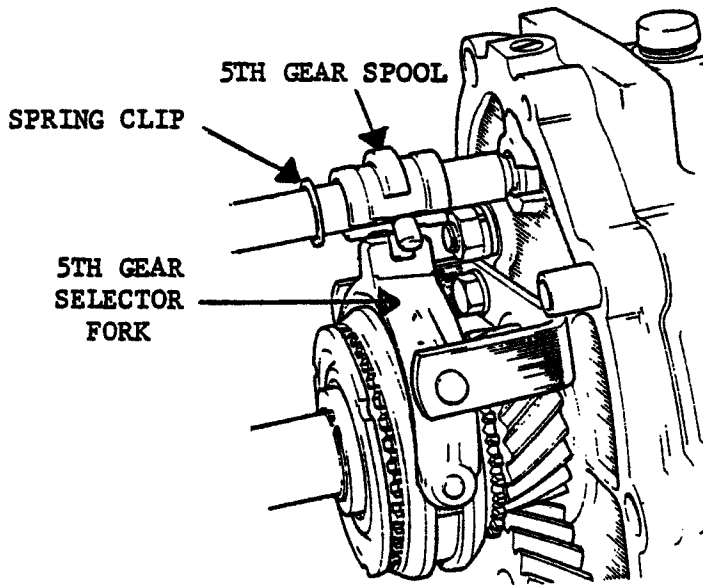

TOOL

74. Rear Extension Housing

Remove 3 bolts and withdraw pump and pick up tube assembly.

10mm Socket

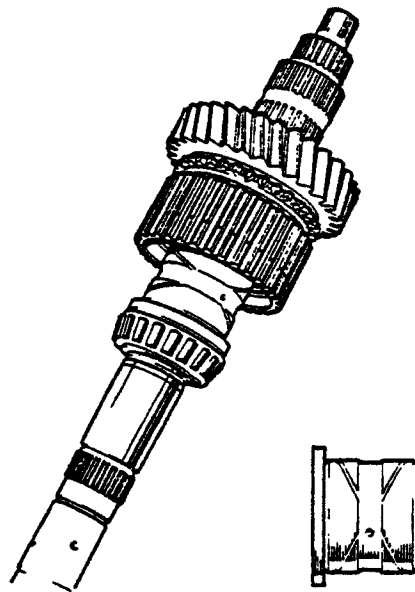

Remove from housing:

Speedo drive

Spacer

Bearing

Seal

75. Check that oil ways are clear.



TOOL

76. Check pump gears and ferobestos bush for wear and damage. Replace selector rail rubber 'O' ring.

NOTE: The boss on extension housing for retaining reverse shaft.

77. Replace pump and copper pick up tube. Insert square drive into pump.

78. Remove 4 dummy bolts from center plate, attach gasket and fit rear extension engaging pump drive into square on layshaft. Two longer bolts to dowel location. Torque 18 lbs/ft.

13mm Socket

Torque Wrench

79. Refit 5th speed selector spool retainer.

10mm Socket

80. Fit speedo drive to mainshaft ensuring flats are in alignment and lead facing correct way, square recesses to the rear. Slide speedo drive onto location finally positioning the collar down shaft. If this procedure is not followed, speedo drive can be drifted too far down shaft and damaged. Lubricate rear bearing and tap into location using drive flange. Tap in seal flush, oiling lip for initial lubrication.

Hammer Drift

	<u>TOOL</u>
81. Push on drive flange, tighten nut to 150 lbs/ft.	27mm Socket Torque Wrench 18G1205
82. Through access hole replace coupling pin, plain washer and nyloc nut.	13mm Socket
83. Finally attach bell housing fitting plain washers to longer bolts which go into the dowel locations. Torque 55 lbs/ft. Fit clutch fork and bearing.	19mm Socket 19mm Crowfoot Torque Wrench
84. <u>Adjustment of Gear Lever Bias Spring</u>	
a. * With unit completely assembled engage 3rd gear.	
b. Adjust the bolts to position both legs of spring 0.5mm - .020" clear of lever cross pin.	13mm OE Feeler Gauge
c. Apply a light load to lever in LH direction taking up play. Adjust RH bolt downward until RH spring leg just makes contact with cross pin.	13mm OE
d. Repeat operation on other side (hold lever to right and adjust LH bolts).	13mm OE Feeler Gauge
e. Play will still be present, but at extremes the cross pin should make contact with the spring legs.	
f. Return lever to neutral and rock across gate several times. Lever should return to 3rd/4th gate.	
g. Tighten lock nuts.	13mm OE

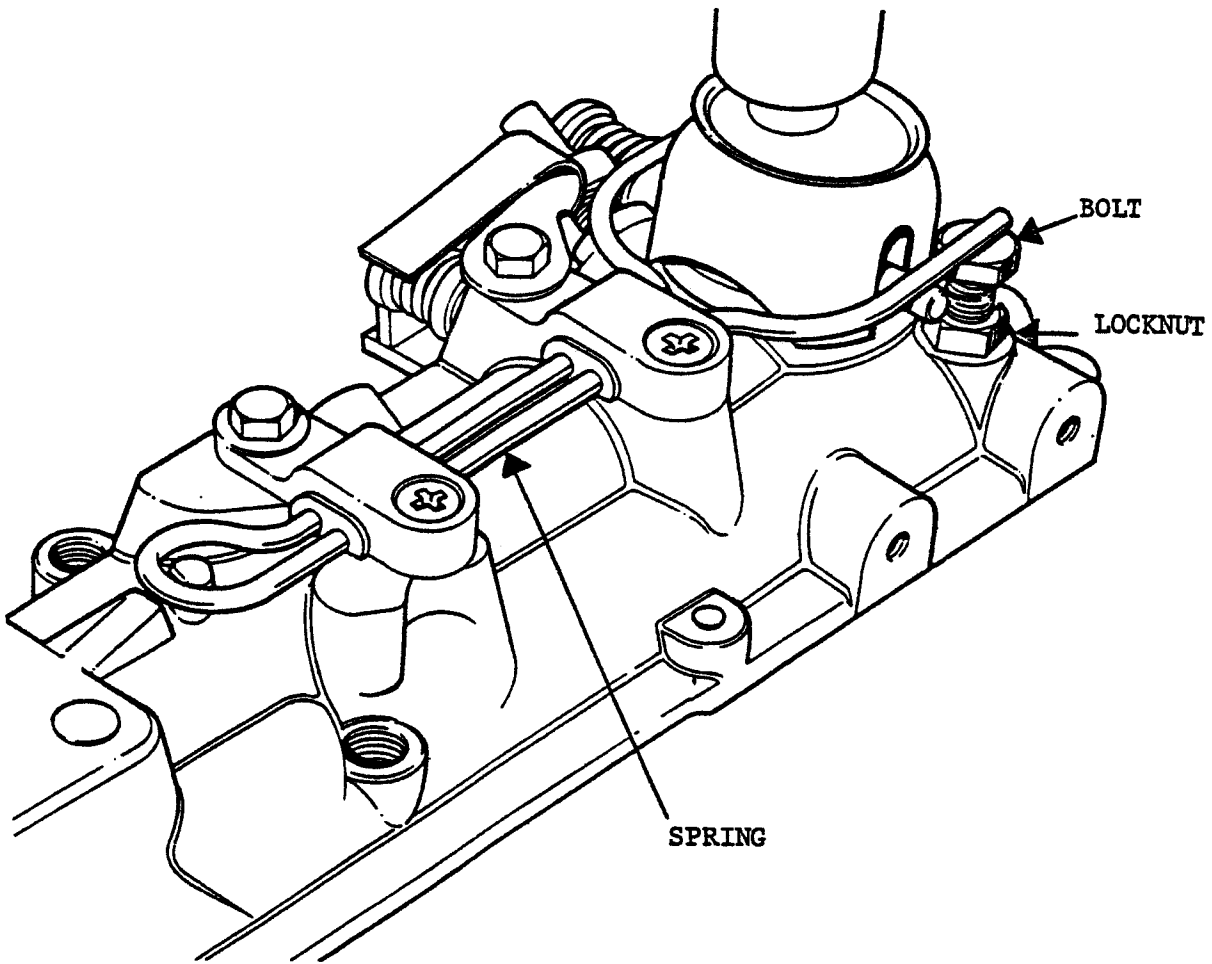

TOOL

85. Reverse Light Switch Adjustment

a. Connect the test lamp and battery (or  
ohmmeter) to the switch. 15mm OE  
14mm OE

b. Select reverse gear. Screw the switch  
inwards until the lamp just comes on.  
Screw the switch in a further 180° and  
tighten the locknut. Check that the light  
does not come on in any other gear.

86. Adjust reverse baulk plate tension bolts. 10mm OE

With gear lever in neutral, attach a spring  
balance to the lever 24cm (9½ in.) from the  
cross pin. Spring Balance

A pull of 11.00 to 13.00 kg (25 - 30 lbs.) is  
required to overcome the baulk plate. Adjust  
bolts equally as necessary.

